

501: Uitbouw 1,2m

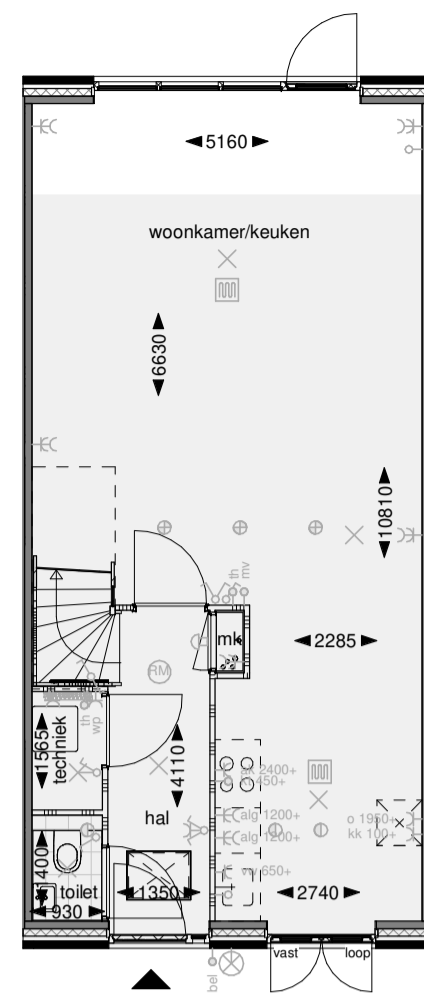

Begane grond



Achtergevel

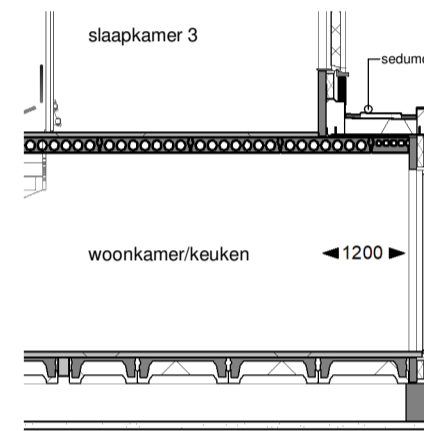

Doorsnede

bnr. 30, 31, 34, 35

512: Dubbele deuren achtergevel

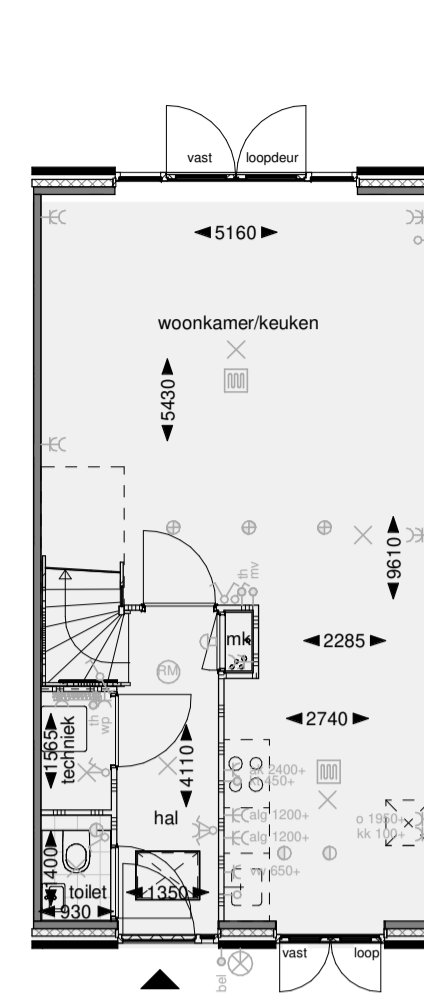

Begane grond



Achtergevel



Doorsnede

bnr. 30, 31, 34, 35

541: Dakraam voor- en achtergevel

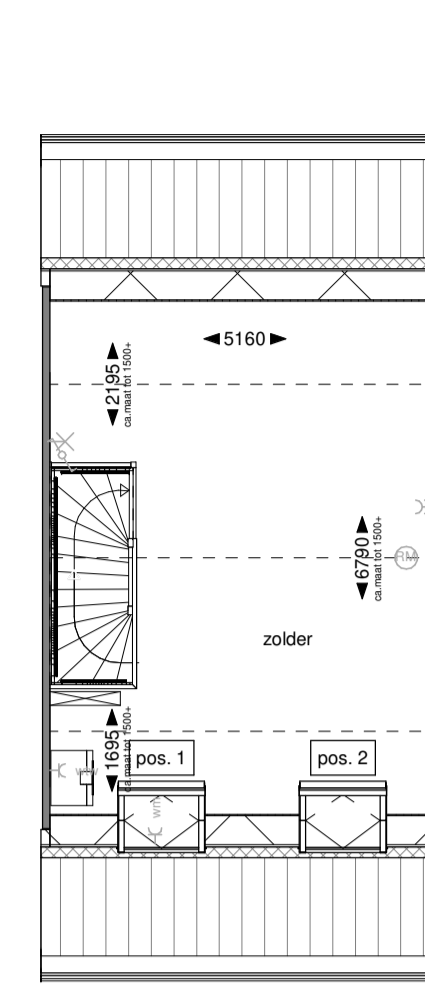

Tweede verdieping
bnrs. 34+35



Voorgevel

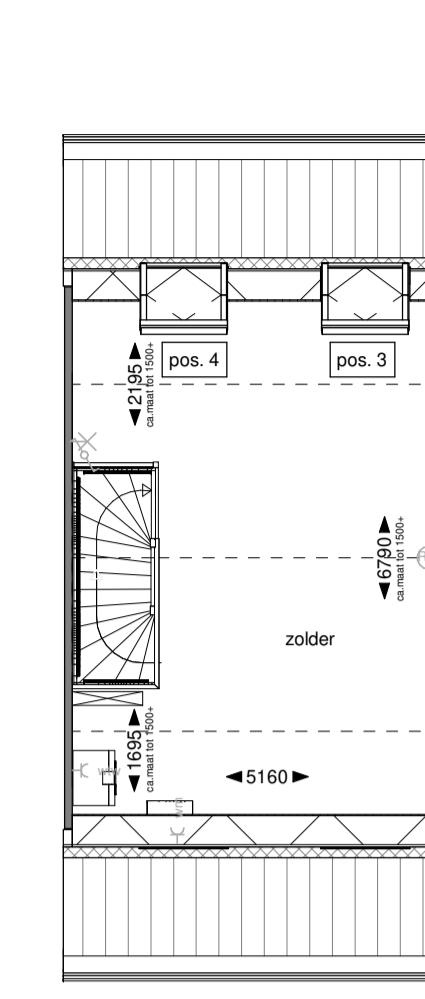

Tweede verdieping
bnrs. 30+31



Achtergevel

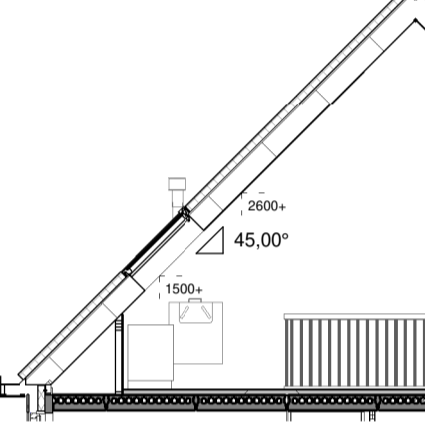

Doorsnede

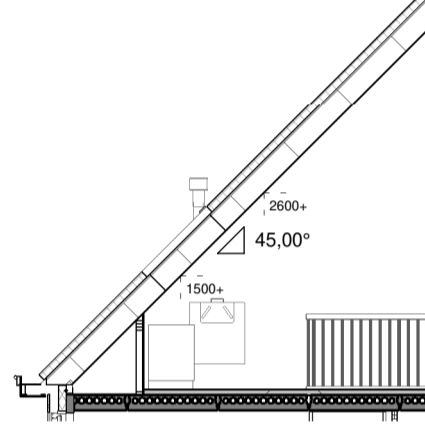

Doorsnede

vanwege PV-panelen:
bnrs. 34+35 alleen voorgevel mogelijk
bnrs. 30+31 alleen achtergevel mogelijk
bnrs. 30, 31, 34, 35

502: Uitbouw 2,4m

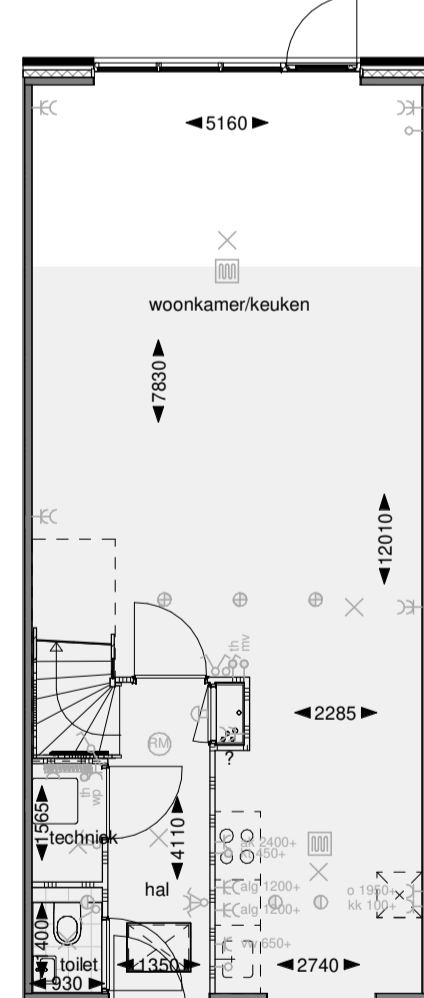

Begane grond



Achtergevel

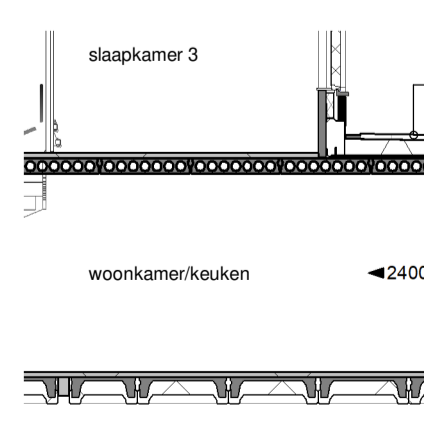

Doorsnede

bnr. 30, 31, 34, 35

531: Dakkapel voorgevel

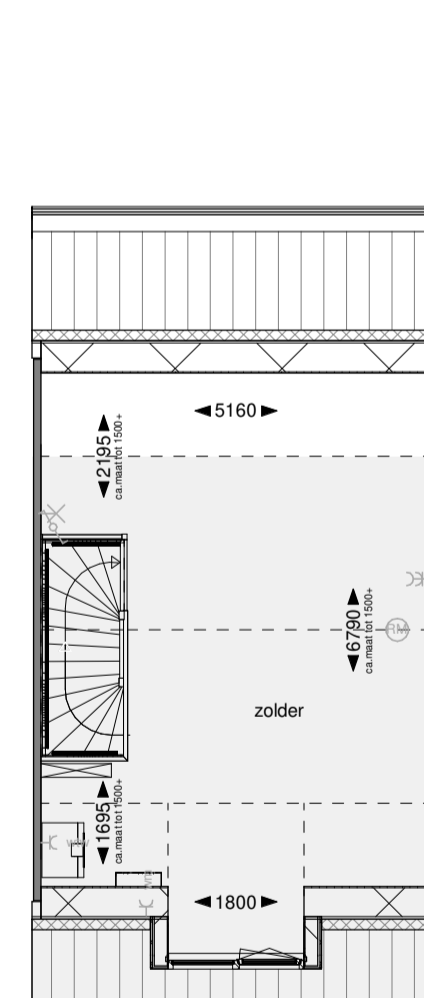

Tweede verdieping



Voorgevel

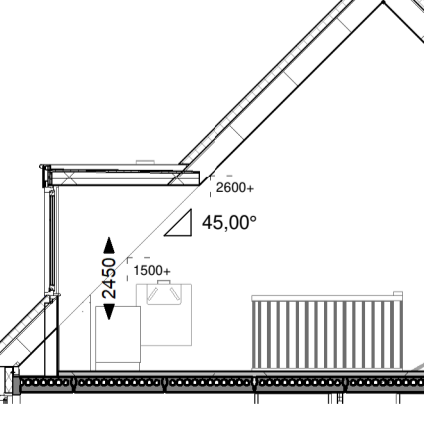

Doorsnede

vanwege PV-panelen:
bnrs. 34+35 alleen voorgevel mogelijk

532: Dakkapel achtergevel

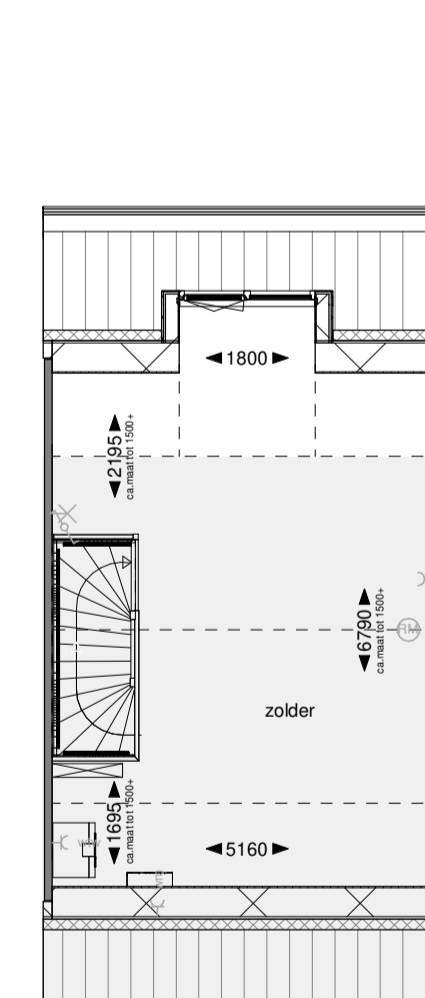

Tweede verdieping



Achtergevel

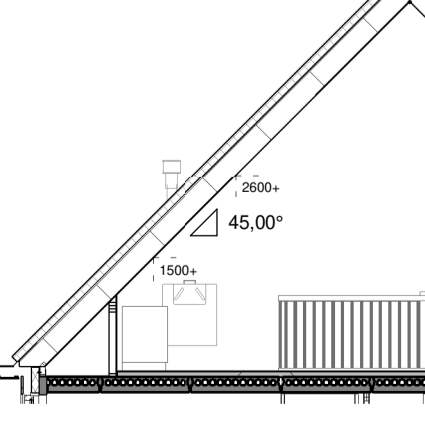

Doorsnede

vanwege PV-panelen:
bnrs. 30+31 alleen achtergevel mogelijk

De gevelweergave is een voorbeeldweergave en verschilt per bouwnummer

Hollandse Weelde
WESTERGOUWE - GOUDA

	Project: Westergouwe veld 11 Bladomschrijving: Opties exterieur V.54.10 (Bnr. 30+31+34+35) Bladnummers: VT-Q-09	schaal: 1:100 datum: 26-07-2024 gewijzigd: A B C D
--	---	--

601: Trapkast begane grond

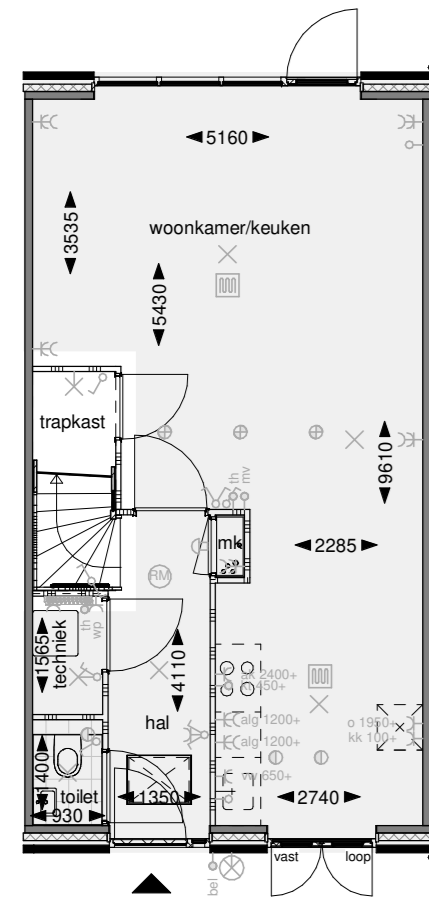

Begane grond

bnrs. 30, 31, 34, 35

702A: Badkamer midden

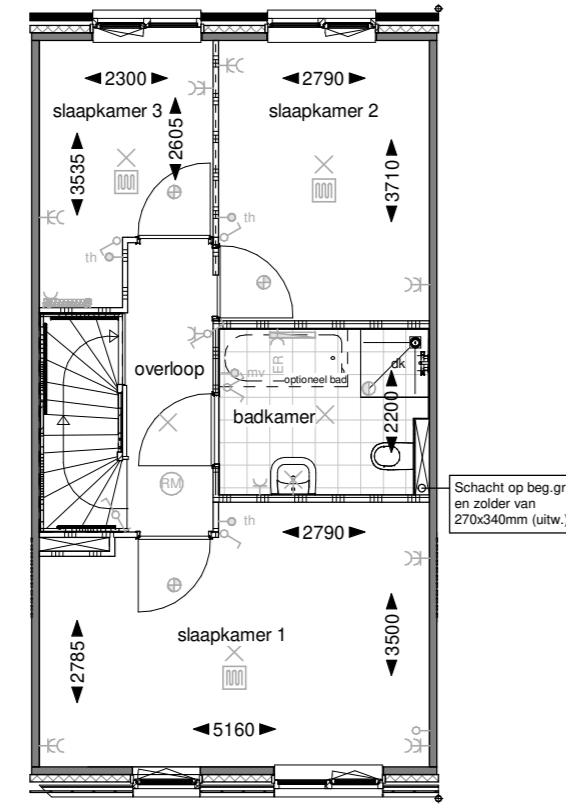

Eerste verdieping

Schacht op beg. gr. en zolder van 270x340mm (uitw.)

bnrs. 30, 31, 34, 35

801: Vliering (langskap)

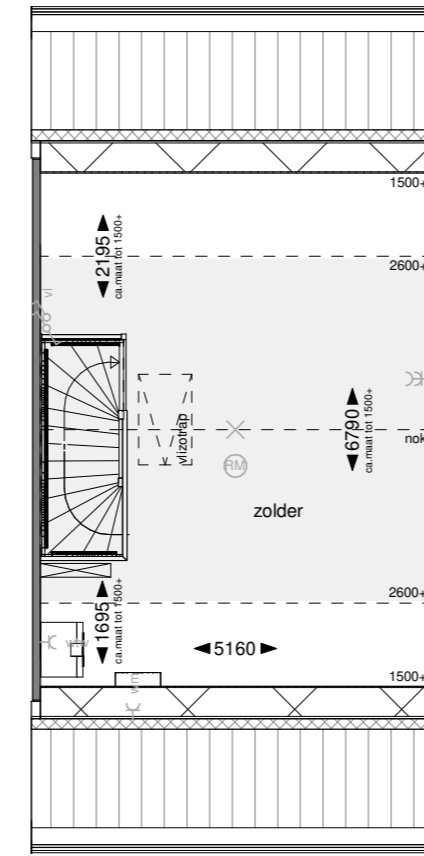

Tweede verdieping

bnrs. 30, 31, 34, 35

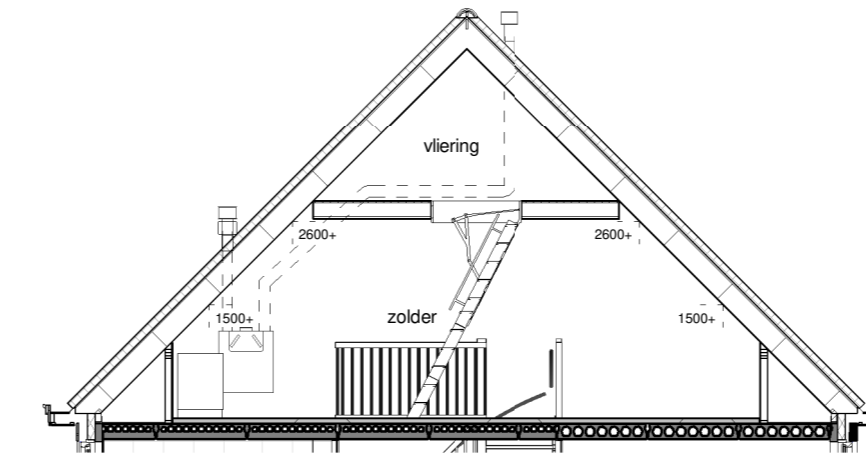

Doorsnede

821: Zolderindeling 2 (langskap)

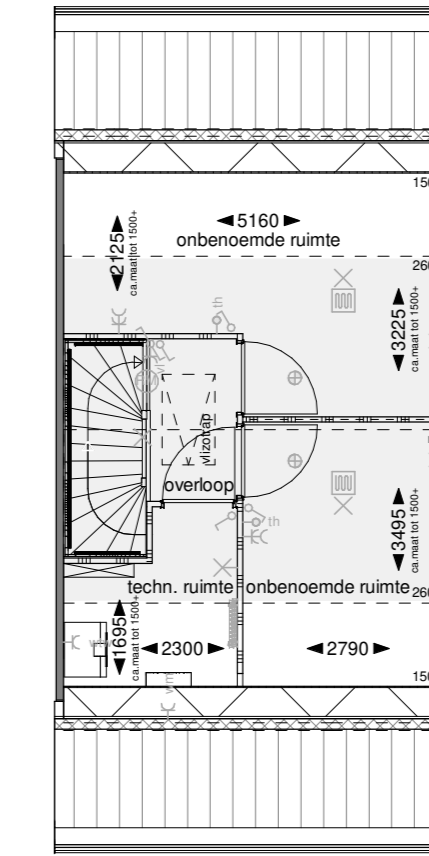

Tweede verdieping

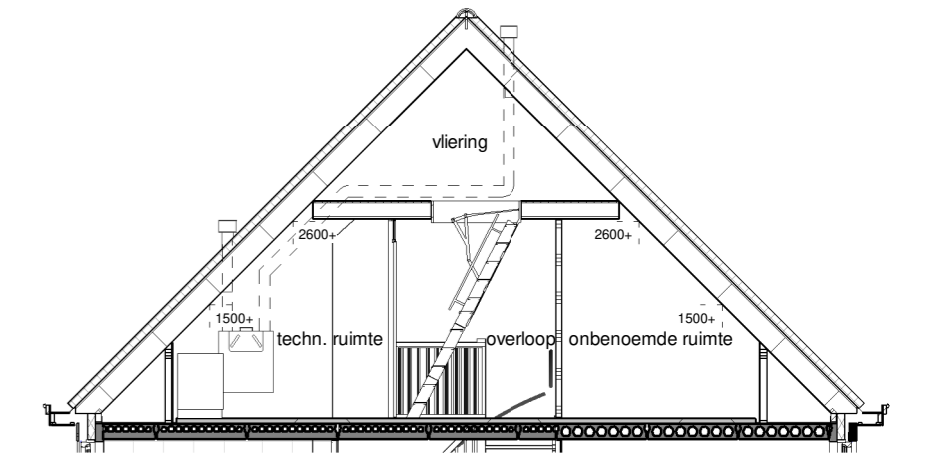

Doorsnede

bnrs. 30, 31, 34, 35

701: Badkamer vergroten

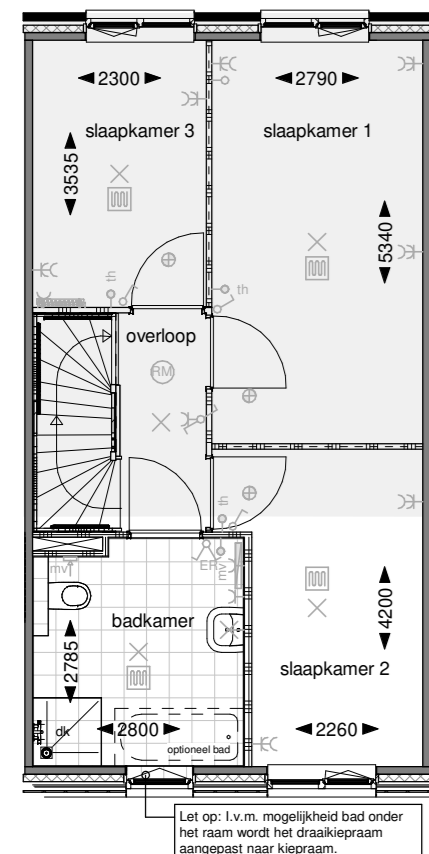

Eerste verdieping

bnrs. 30, 31, 34, 35

Let op: i.v.m. mogelijkheid bad onder het raam wordt het draakkepraam aangepast naar hoekraam.

702B: Vergroten badkamer midden

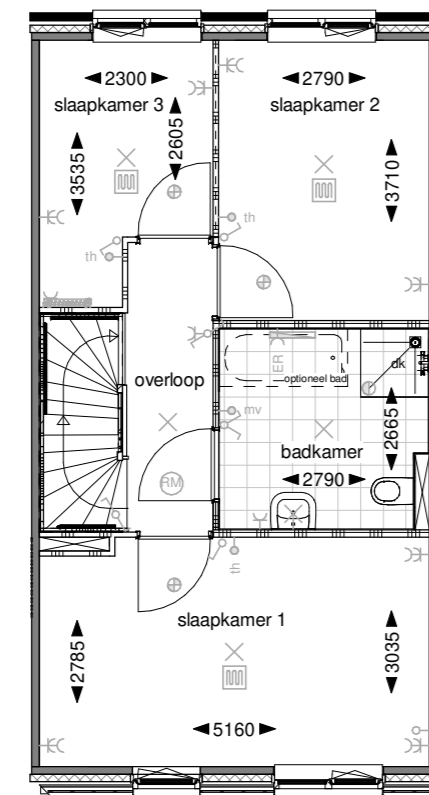

Eerste verdieping

Optie alleen mogelijk i.c.m. optie 702A
bnrs. 30, 31, 34, 35

710: Samenvoegen slaapkamer 1+3

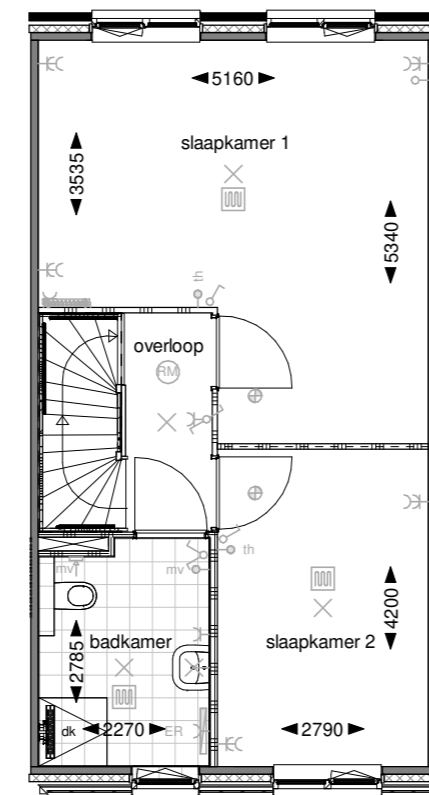

Eerste verdieping

bnrs. 30, 31, 34, 35

811: Zolderindeling 1 (langskap)

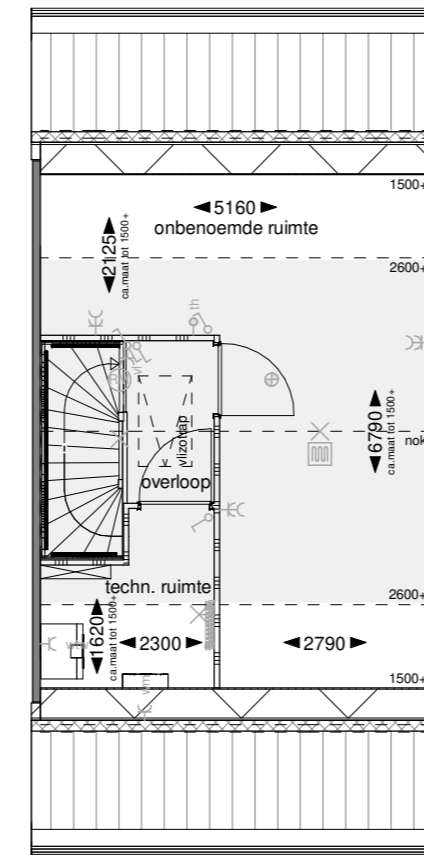

Tweede verdieping

bnrs. 30, 31, 34, 35

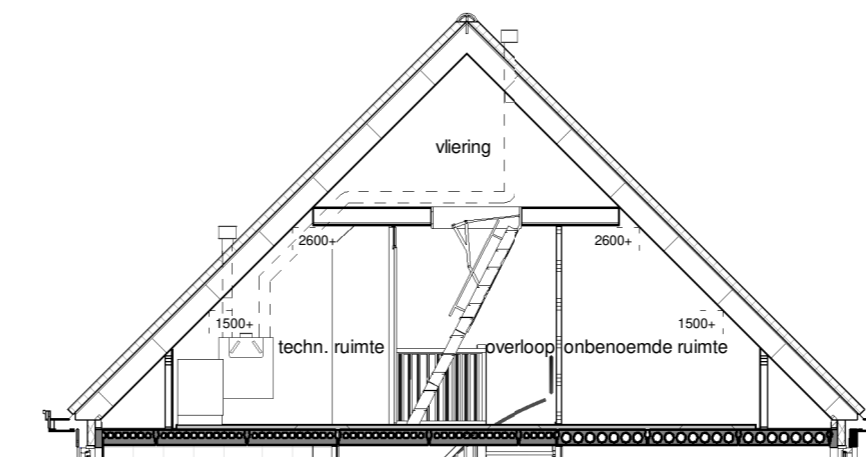

Doorsnede

De gevelweergave is een voorbeeldweergave en verschilt per bouwnummer

Hollandse Weelde
WESTERGOUWE - GOUDA



Project:
Westergouwe veld 11
Bladomschrijving:
Opties interieur V.54.10
(Bnr. 30+31+34+35)
Bladnummer:
VT-O-10

schaal: 1:100
datum: 26-07-2024
gewijzigd:
A
B
C
D